



HITPOINT

SPECIFICATION

PRODUCT TYPE: PMOF-9767NW-46UQ

(RoHS)

DSND BY		
CHKD BY		
APVD BY		

光 键 股 份 有 限 公 司

HITPOINT INC.

Add: No.4, Lane 505 ,Zhongzheng Road, Linkou Shiang, Taipei,Taiwan24445

Tel: + 886-2-2601-3311

FAX : + 886-2-2601-3898

<http://www.hitpoint.com.tw/>

1 Name: Omnidirectional Electret Condenser Microphone (Foil Electret Type)

2 TYPE: PMOF-9767NW-46U

3 Electrical Specifications:

3.1	Sensitivity Range	-46±2dB RL=2.2K Ω Vs=4.5V (1KHz 0dB=1V/Pa)
3.2	Impedance	Max.2.2K Ω 1KHz (RL=2.2K Ω)
3.3	Frequency	20-16000 Hz
3.4	Current Consumption	Max.0.5mA
3.5	Operation Voltage Range	1.0V-10V
3.6	Max. Sound Pressure Level	120dB S.P.L
3.7	S/N Ratio	More than 58dB
3.8	Sensitivity Reduction	4.5V-3.0V Sensitivity Variation less than 3dB

3.9 Typical Frequency Response Curve:

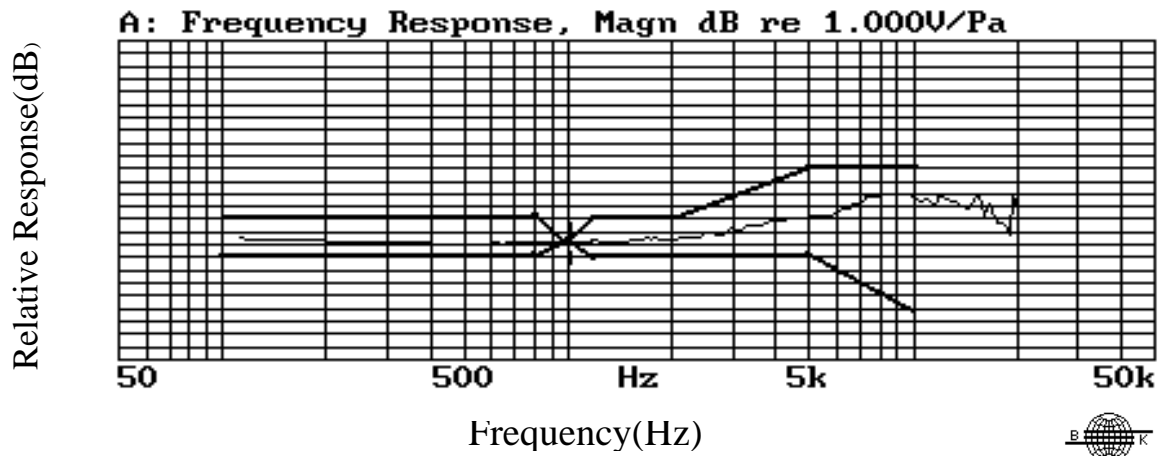

3.10 Schematic Diagram:

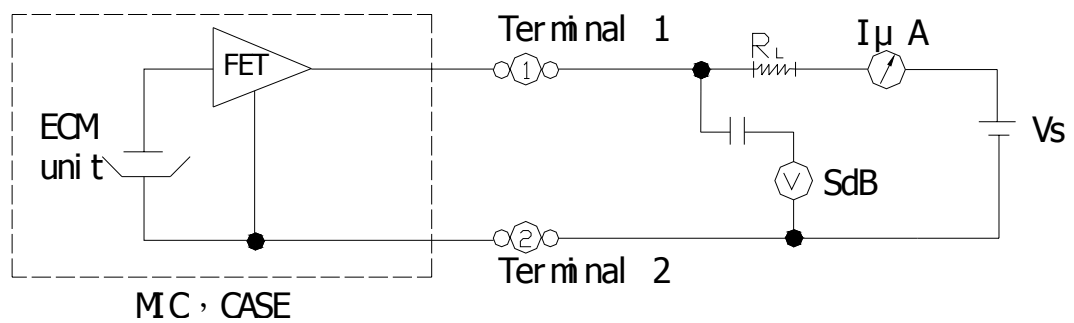

4 Mechanical Specifications:

4.1 Drawing

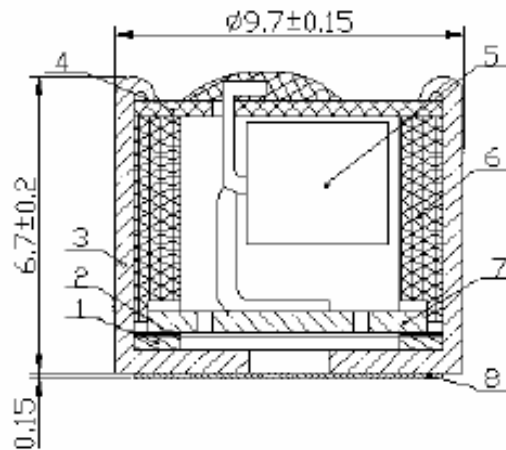

NO.	NAME	MATERIAL	QTY	REMARK
8	FELT	Cotton decon textile	1	
7	ELECTRET BOARD	H62	1	
6	INNER HOUSING	ABS	1	
5	F. E. T		1	28K596
4	P. C. B	Glass fiber	1	
3	CASE	AL	1	
2	SPACER	Polyster film	1	
1	POLARIZED DIAPHRAGM	Teflon	1	DUPONT

4.2 Dimension (mm):

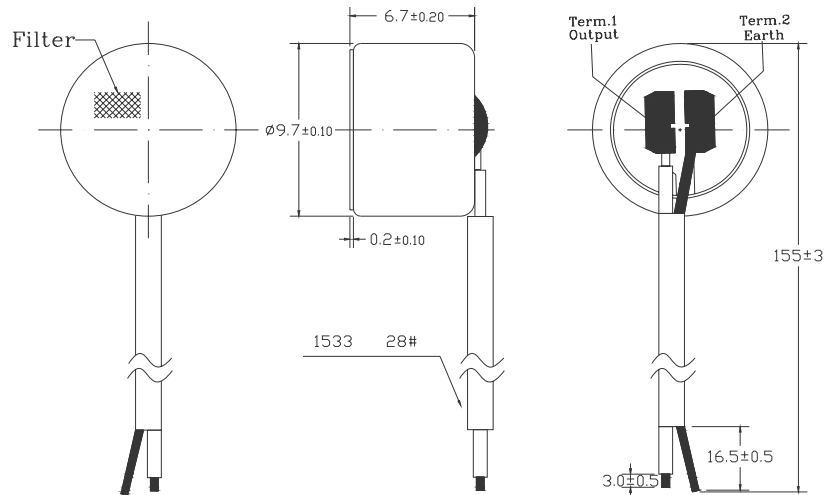

4.3 Weight 1.2g

5. Reliability Tests: After any following tests, the sensitivity of the microphone unit shall not change more than $\pm 3\text{dB}$ from initial value, and shall keep their initial operation and appearance.

5.1	Hi-Temp. Test	The microphone unit must be subjected to $+70^\circ\text{C}$ for 200 Hours, and expose to room temperature for 3 Hours.
5.2	Low-Temp. Test	The microphone unit must be subjected to -25°C for 200 Hours, and expose to room temperature for 3 Hours.
5.3	Humi.&Heat Tes	The microphone unit must be subjected to $+40^\circ\text{C}$, 93% RH-for 200 Hours, and expose to room temp for 3 Hours .
5.4	Humidity Shocking Test	The microphone unit must be subjected to following conditions ($+50^\circ\text{C}$ 1H-room temp 1H; -10°C 1H-room temp 1H) at 5 cycle, and expose to room temp for 3 Hours.
5.5	Vibration Test	The microphone unit must be subjected to a procedure that after vibrating for two hours from each of the two directions with a frequency of 10-55Hz and a 1.52mm-high amplitude.
5.6	Dropping Test	The microphone unit must be subjected to a procedure that after dropping to a slippery marble floor for 5 times from a 1-meter-high without package.

6 Environmental Condition:

6.1 Storage condition $-20^\circ\text{C} \sim +60^\circ\text{C}$ R.H. 45%--75%

